



Solenoid valves for fuel dispensers

3 way -2 stage solenoid valve

Model No.: IN 4111 F



TECHNICAL SPECIFICATION :

Type	: 3 Way -2 stage solenoid valve(NC)
Port size	: Flange
Period	: Continuous
Insulation class	: F
Working fluid pressure	: 0.35 bar to 3.5 bar
Body material	: Aluminium
Diaphragm	: FPM (Fluoroelastomer)
Orifice	: 2.5 mm / 25 mm
Operating voltage	: 230V AC / 24V DC / 12V DC
Wattage	: 2 x 6.9W (230V) & 2 x 6.25W (24V DC) & 2 x 6.8W (12V DC)
Fluid media	: Petrol / Diesel
Ambient temp.	: -40°C to +65°C
Approvals	: ATEX, IECEX, PESO

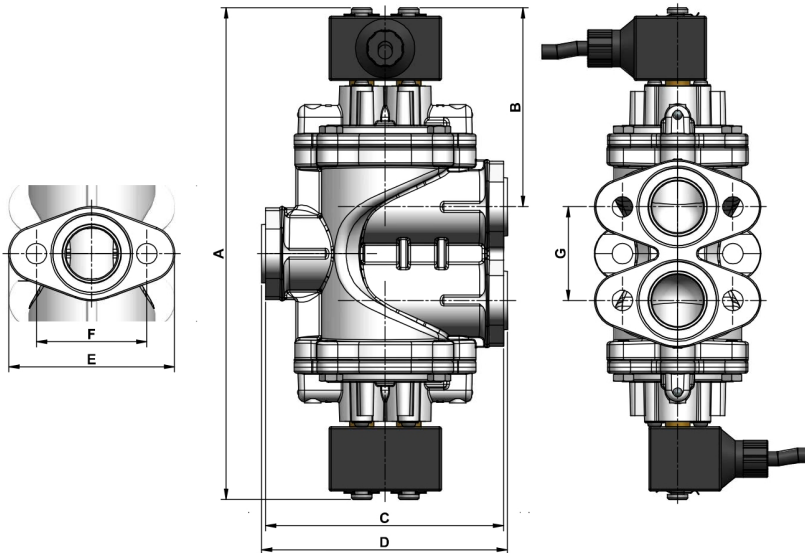

Dimensions are in mm

Model No	Port Size	A	B	C	D	E	F	G
IN 4111 F	Flange	239.8	97	117	120.7	81.2	54	45.8